

THE OBSTACLE COURSE

The length of the obstacle course is 500 m. The track comprises 20 obstacles placed at 10 m intervals at least.

Each lane should have a width of 2.50 m. The minimum width is 2 m. The course must be measured 0.3 m from the inner edge. The actual running distance is not taken into account (e.g. obstacle no. 19).

The form of the course is left to the discretion of the organiser depending upon the area available.

For World and Continental Championships a course with at least two lanes must be ensured.

The surface must be firm. The prepared earth in the landing pits shall be flat. Heaped up sand should be avoided.

Lines marking the beginning and the end of an obstacle are part of the obstacle. It is not permitted to touch lane lines, delineating the inner edge of the curve of a lane. At least four identical cones will be placed in the curves.

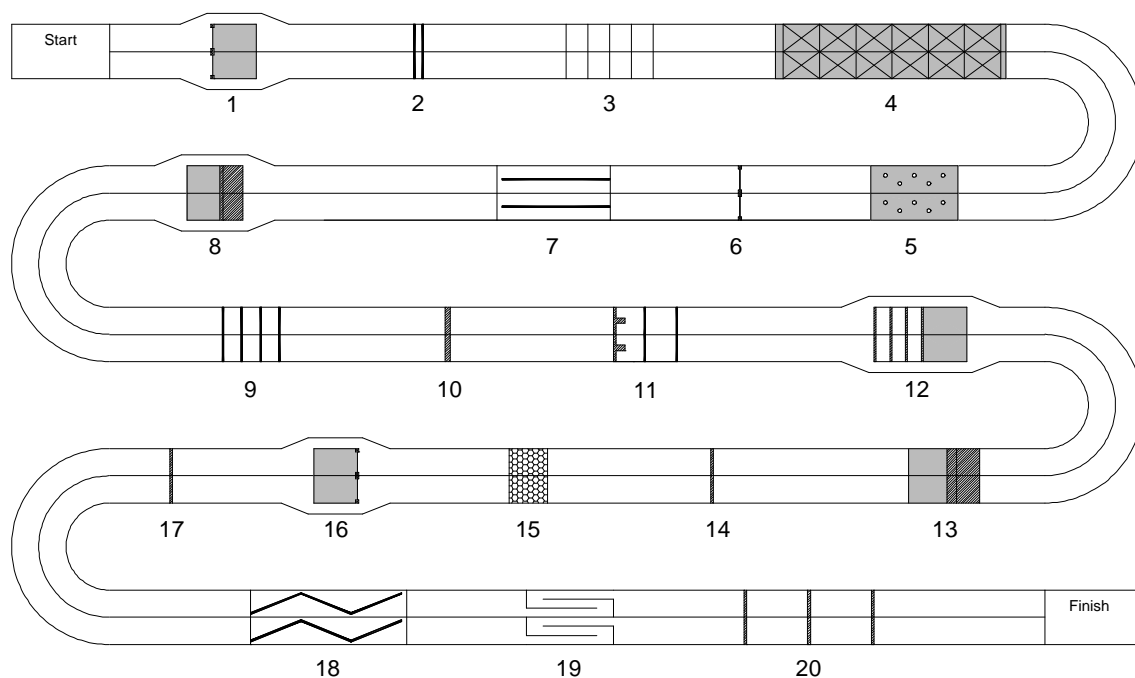

1. DESCRIPTIONS OF THE OBSTACLES

All measurements which are not mentioned below explicitly (see characteristics) are according sketch. All dimensions in the sketches are given in meters.

Remark:

Within the tolerance permitted (9.0 – 11.0 cm) for the bars at obstacles no. 1, 6, and 16 standardised tubes are available internationally in the following dimensions: 9.3 cm; 10.16 cm; 10.40 cm; 10.80 cm

Within the tolerance permitted (11.0 – 13.0 cm) for the beams at obstacles no. 2, 9, and 11 standardised tubes are available internationally in the following dimensions: 11.43 cm; 12.7 cm

OBSTACLE 1

ROPE LADDER

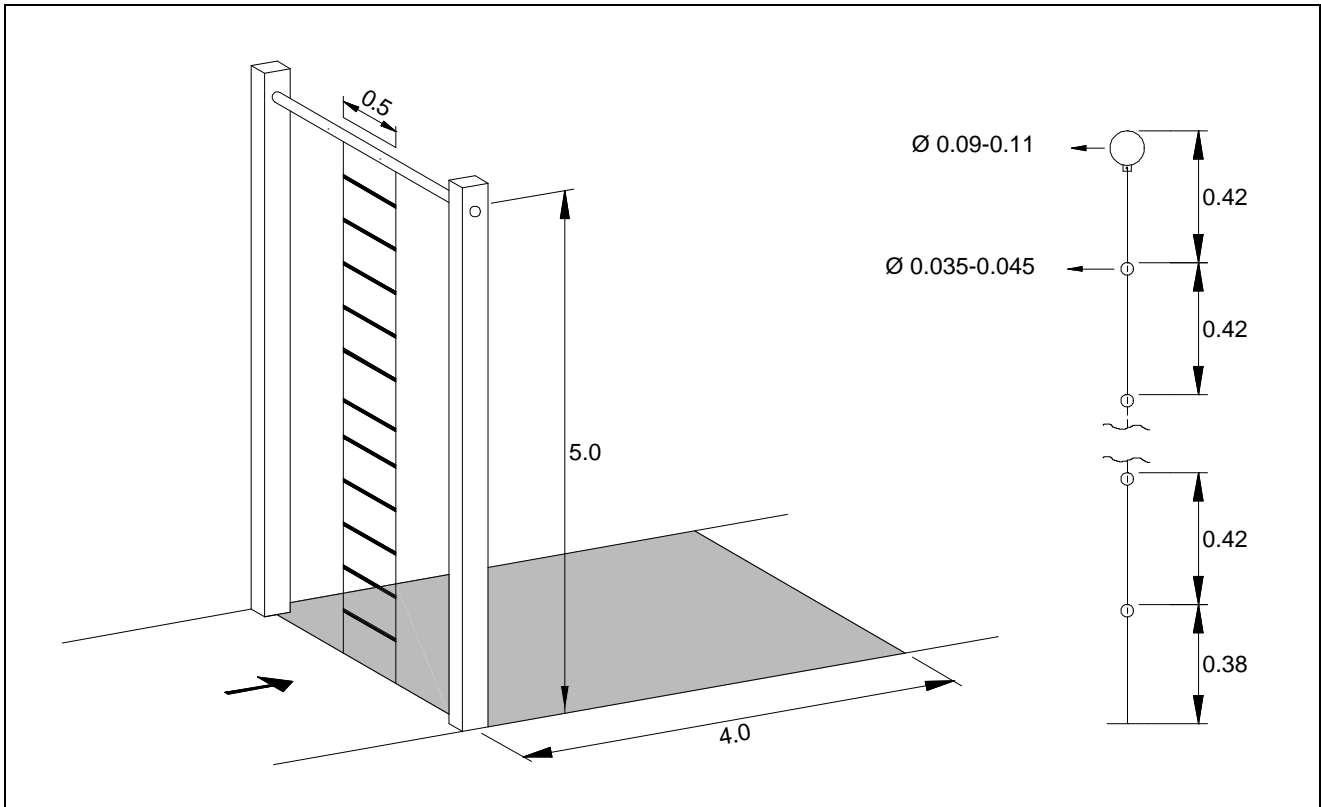

Characteristics

The ladder must be fixed to the earth.

Height.....	5.0 m
Number of rungs	11
Width of rungs	0.5 m
Diameter of rungs	3.5 - 4.5 cm
Diameter of crossbar (must be tubular)	9.0 - 11.0 cm
Length of landing pit.....	4.0 m

The distance between the upper side of the rungs as well as the distance between the last rung and the upper side of the crossbar must be equal (some flexibility because of reasons of construction is possible between ground and first rung only)

To ensure unhindered crossing of the crossbar the ladder must be fixed at the lower edge of the bar only.

It is recommended to expand the firm surface of the lanes on both sides of the obstacle (passages) to enable unhindered passing for female competitors (see page 22 figure 1).

Crossing

Free style climbing.

Cross the bar and descend or jump down to the prepared ground on the opposite side.

OBSTACLE 2

DOUBLE BEAM

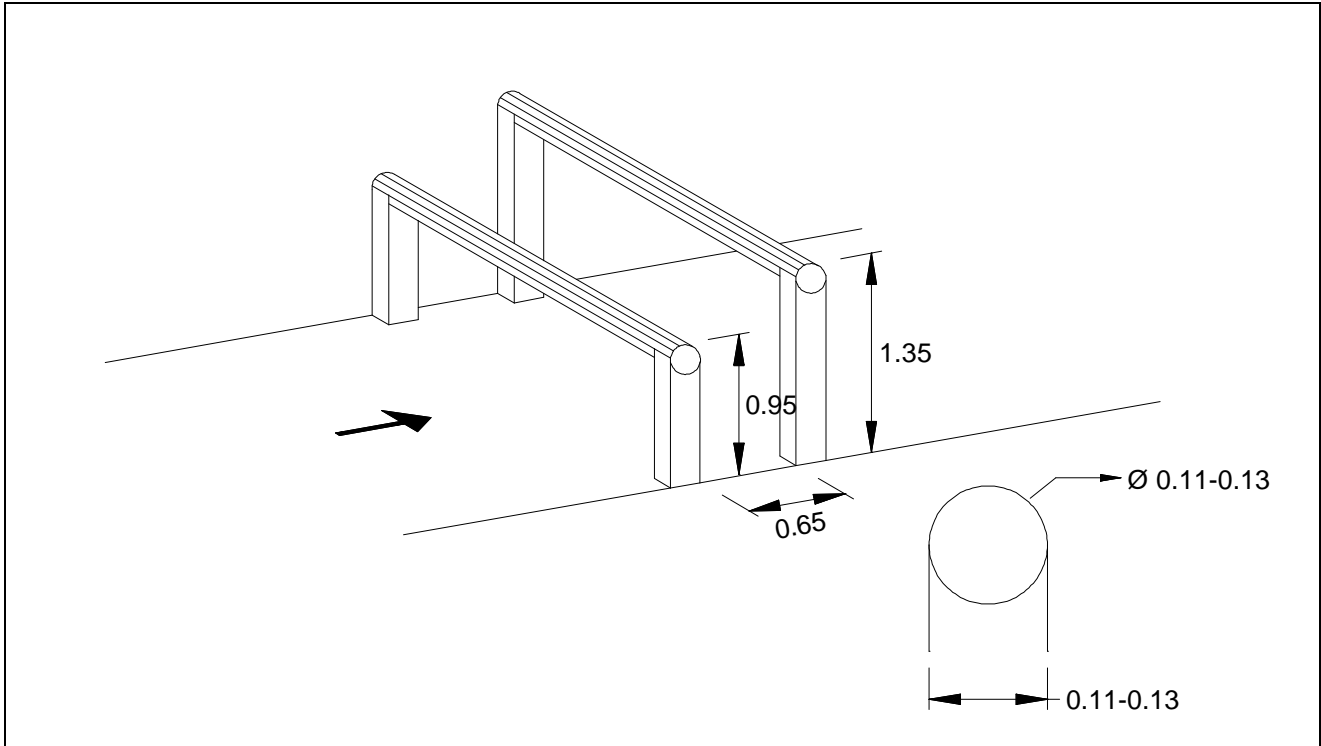

Characteristics

- Height of 1st beam (upper edge).....0.95 m
- Height of 2nd beam (upper edge)..... 1.35 m
- Distance between the beams (horizontal plane)0.65 m
- Dimensions of the beams:
- Diameter of tubular beams 11.0 - 13.0 cm

Crossing

Jump onto the first beam, make contact with the ground between the two beams, then pass over the second beam.

OBSTACLE 3

TRIP WIRE

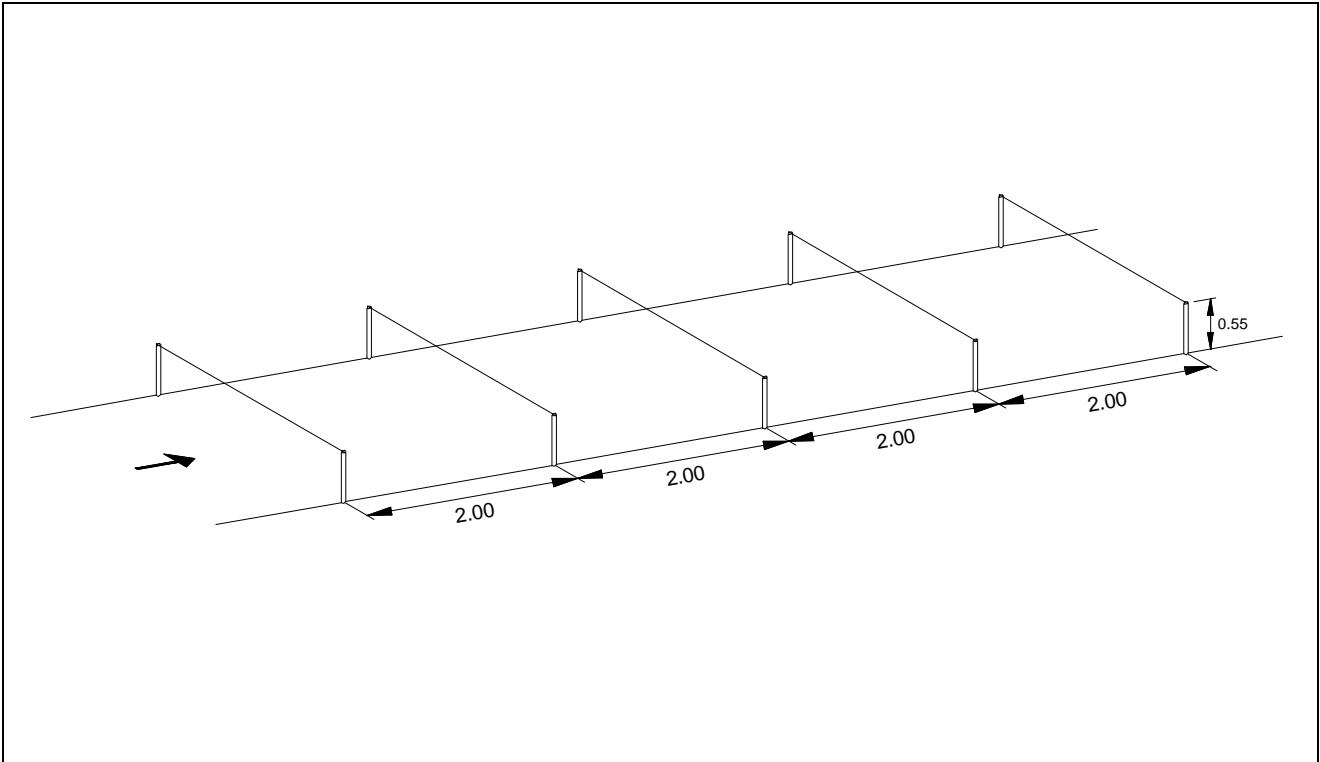

Characteristics

5 elastic wires, coloured or marked to make them very visible and placed at an interval of2.0 m
 Height above ground.....0.55 m
 Diameter of the wire..... minimum 7 mm

Wires in one lane must be fixed independently from wires in other lanes.

Material with limited elasticity will be used. Maximum elasticity shall be 50 cm in running direction.

For safety reasons the wires must be absolutely securely fixed (e. g. snap hook).

Crossing

Wires to be hurdled.

Jump over each one of the 5 wires successively and in a free style.

Touching or stretching the wires is permitted whereas deliberately jumping on the wires is forbidden.

OBSTACLE 4

NETWORK OF WIRES

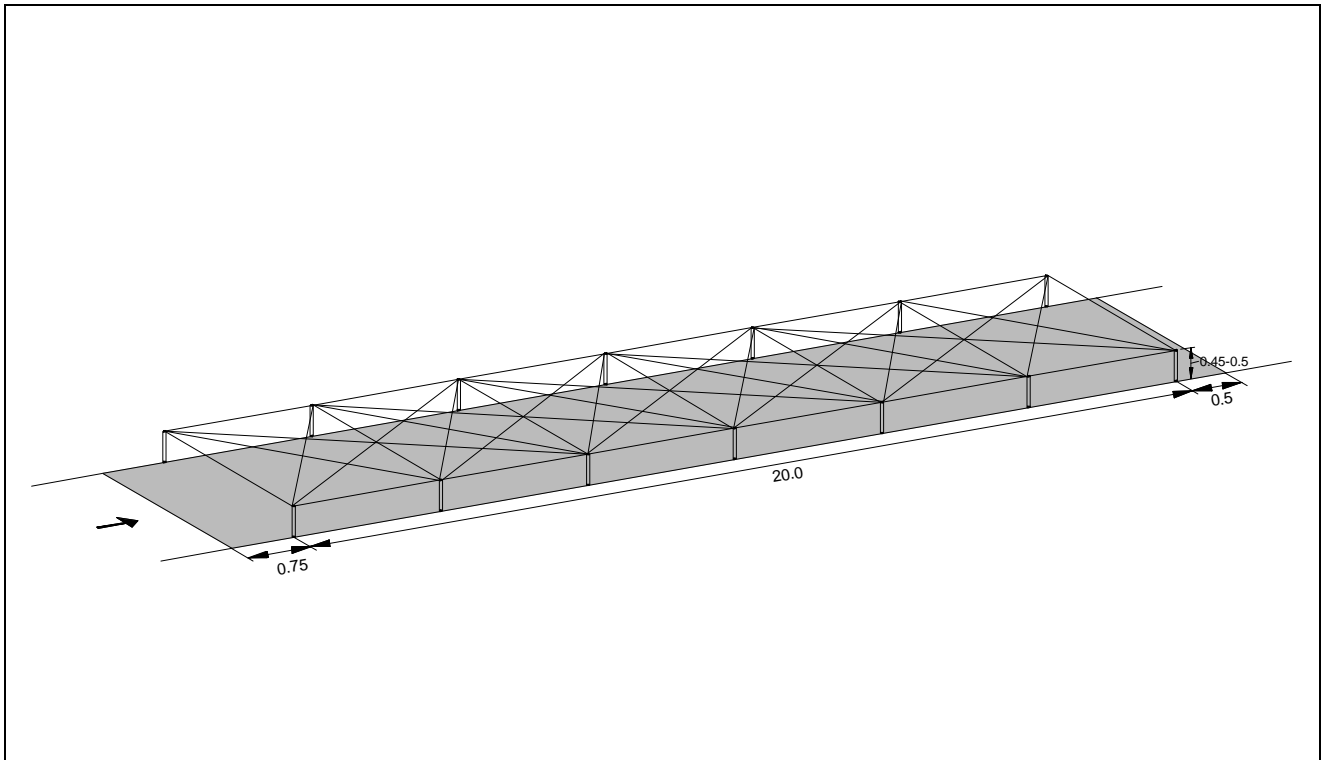

Characteristics

Length of the network20.0 m

Height.....0.45 - 0.5 m

The surface of the ground under the network must be supple and should commence 0.75 m in front of and end 0.50 m behind the network.

The network must be fixed and be of non-stretchable material.

The wires marking the beginning and the end of the network must be of material with some elasticity.

They must be absolutely securely fixed (e.g. snap hook).

Crossing

Free style crawling underneath the network.

OBSTACLE 5

FORD

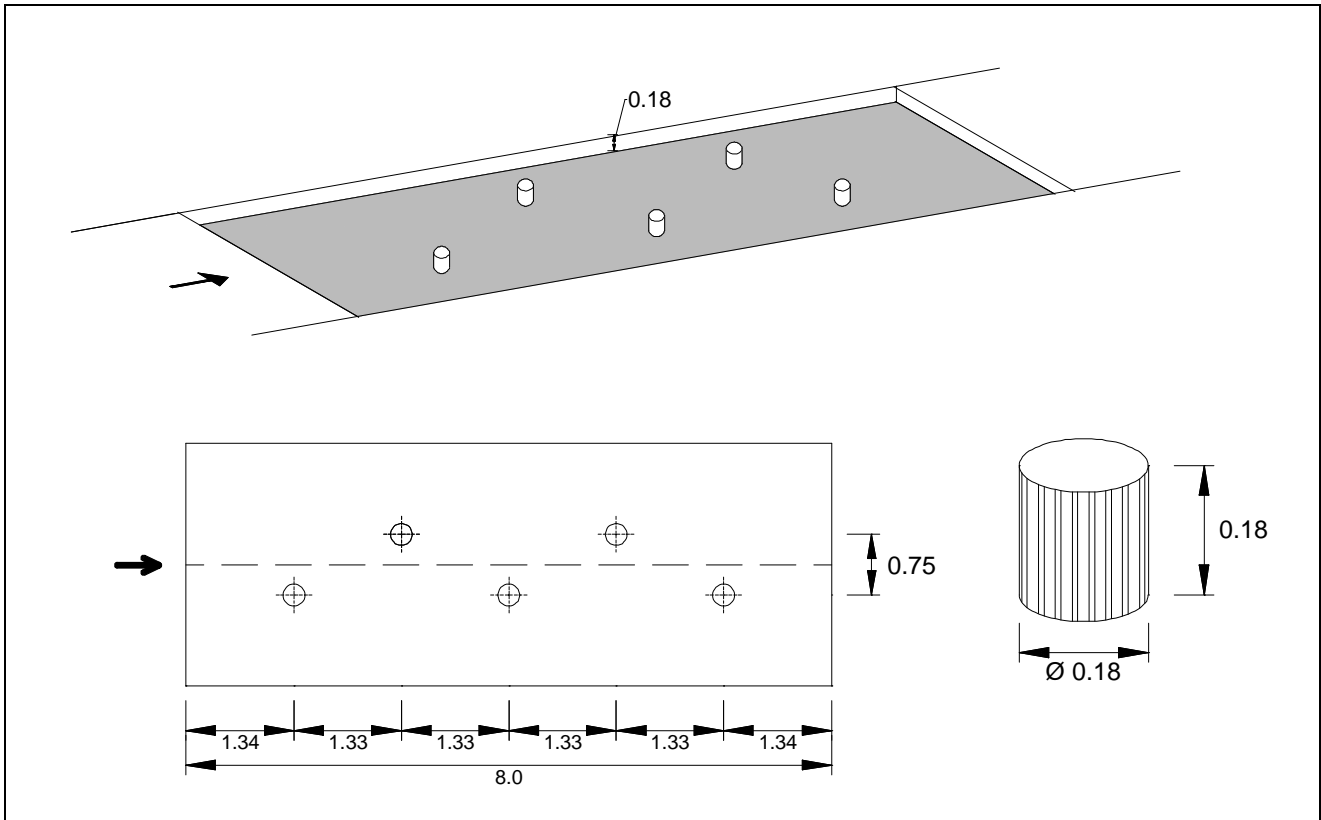

Characteristics

- Length of the ford.....8.0 m
- Depth of the ford0.18 m
- 5 cylindrical plots
- Height.....0.18 m
- Diameter.....0.18 m

The position of the plots must be according sketch (all distances are measured from the centre).

The ground between the plots must be soft so that incorrect passing (stepping on the ground) is detectable.

Crossing

Cross the ford by stepping on the plots only.

It is forbidden to have contact with the ground between the two lines, limiting the ford. In case of contact with the ground the competitor has to recommence in front of the first line. By "having contact" is understood "taking support".

There is no obligation to use all plots.

OBSTACLE 6

ESPALIER

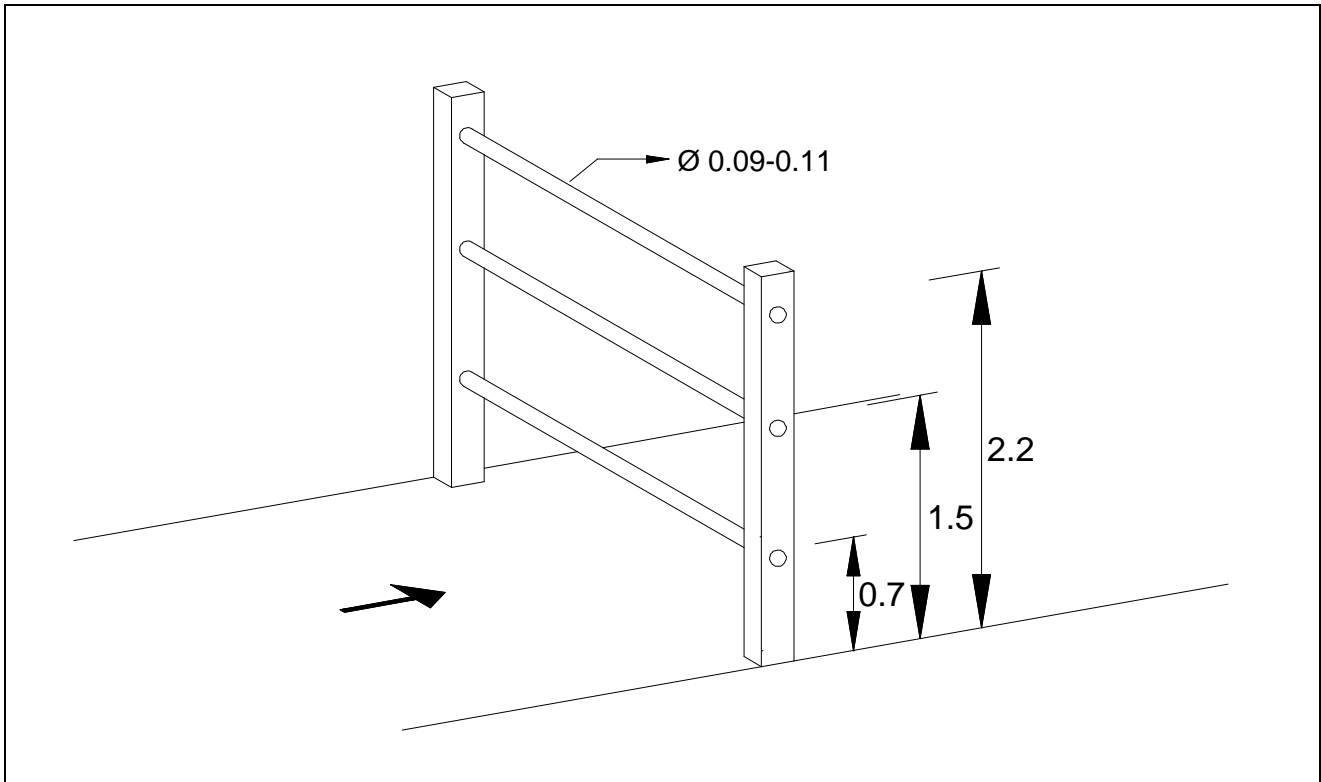

Characteristics

3 horizontal tubular bars

Height of highest bar (upper edge)	2.2 m
Height of middle bar (upper edge)	1.5 m
Height of lower bar (upper edge)	0.7 m
Dimensions of the bars	9.0 - 11.0 cm

Crossing

All styles are permitted provided that the top bar is crossed.

OBSTACLE 7

BALANCE BEAM

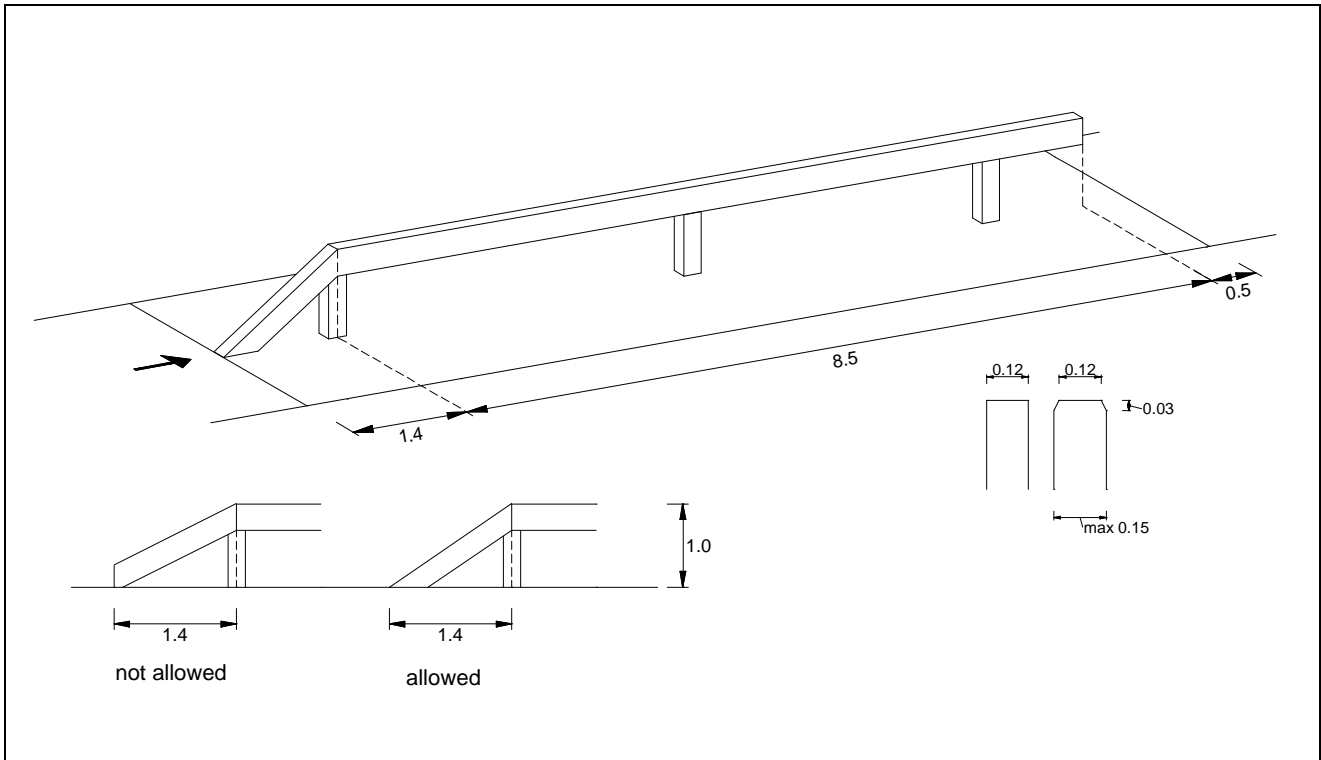

Characteristics

- Total length of the obstacle between the two limiting lines 10.4 m
 - Height of the horizontal beam (upper edge)..... 1.0 m
 - Length of the horizontal beam 8.5 m
 - Ground distance from the beginning of the sloping plank to the beginning of the horizontal beam..... 1.4 m
 - Width of the flat top side and of the sloping blank..... 12 cm
- Two limiting lines (width 5 cm) are part of the obstacle. The first line is placed at the beginning of the obstacle (0 – 5 cm), the other 45 – 50 cm beyond the end of the horizontal beam.

Crossing

Mount the beam ahead of the first line. Cross it lengthwise. At the far end jump to the ground beyond the limiting line.

Between the two lines, all loss of balance resulting in contact with the ground is considered a fault. The competitor must recommence in front of the line, marking the beginning of the obstacle.

OBSTACLE 8

SLOPING WALL WITH ROPE

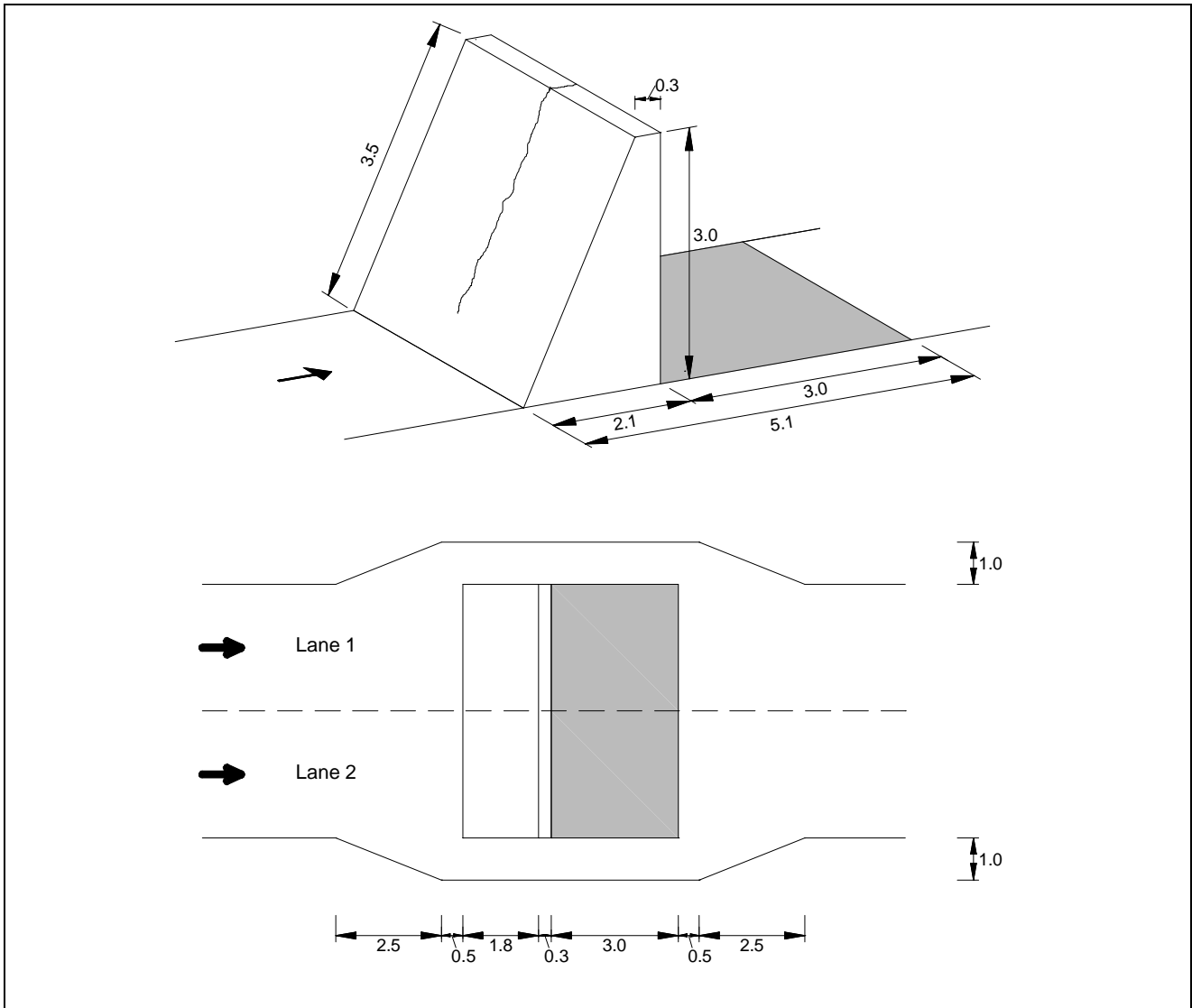

Characteristics

Height.....	3.0 m
Width of the flat top.....	0.3 m
Ground distance of the sloping side	1.8 m
Length of the sloping side of the wall.....	3.5 m
Length of the basis of the wall.....	2.1 m
Length of landing pit.....	3.0 m

It is recommended to expand the firm surface of the lanes on both sides of the obstacle (passages) to enable unhindered passing for female competitors (see page 22 figure 1).

Crossing

Free style climbing, with or without using the rope. Cross the top and jump down to the prepared ground on the opposite side.

OBSTACLE 9

HORIZONTAL BEAMS (OVER-UNDER)

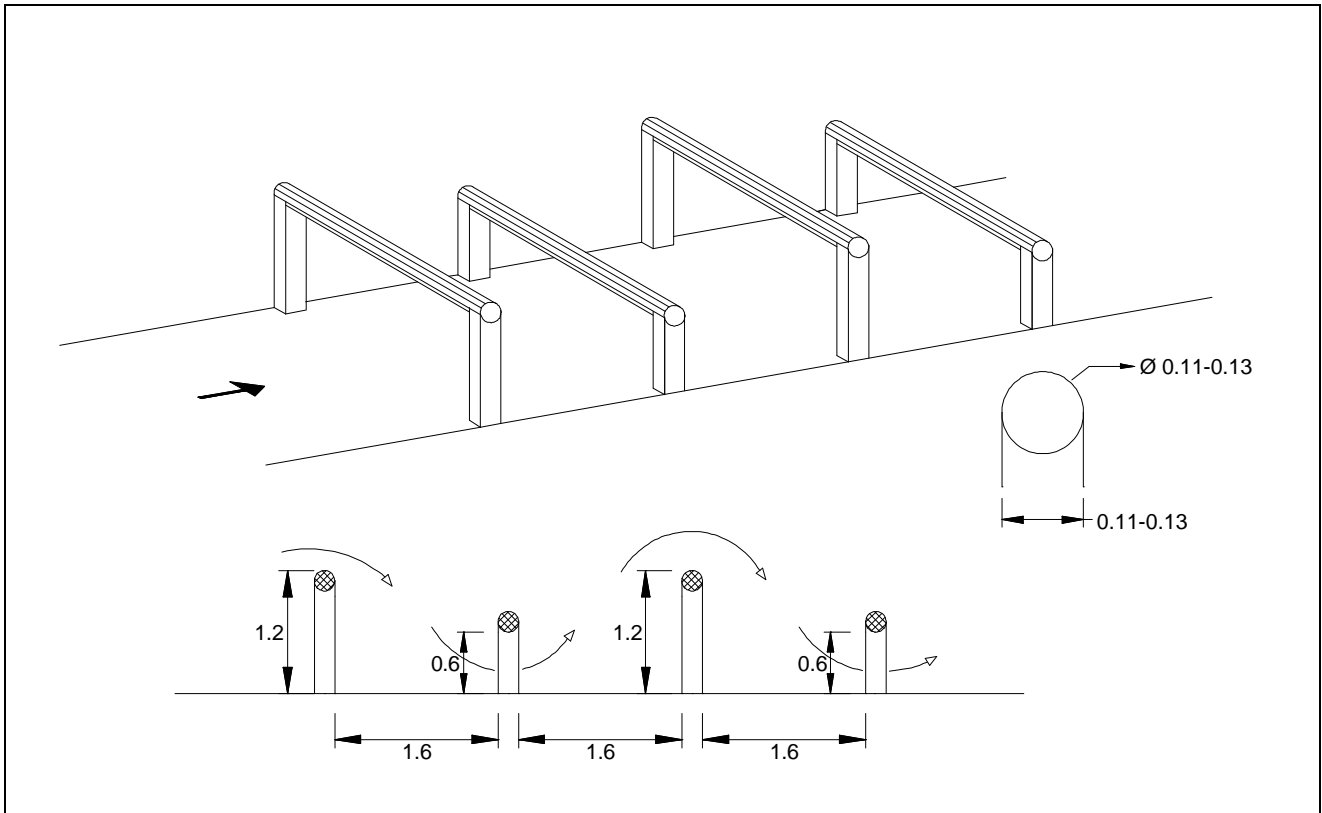

Characteristics

- Height of 1st and 3rd beam (upper edge) 1.2 m
- Free space under 2nd and 4th beam (lower edge) 0.6 m
- Distance between the beams (horizontal plane) 1.6 m
- Dimensions of the beams:
- Diameter of tubular beams 11.0 – 13.0 cm

Crossing

Negotiate the beams in order over - under - over - under, in a style left to the competitor's choice.

OBSTACLE 10

IRISH TABLE

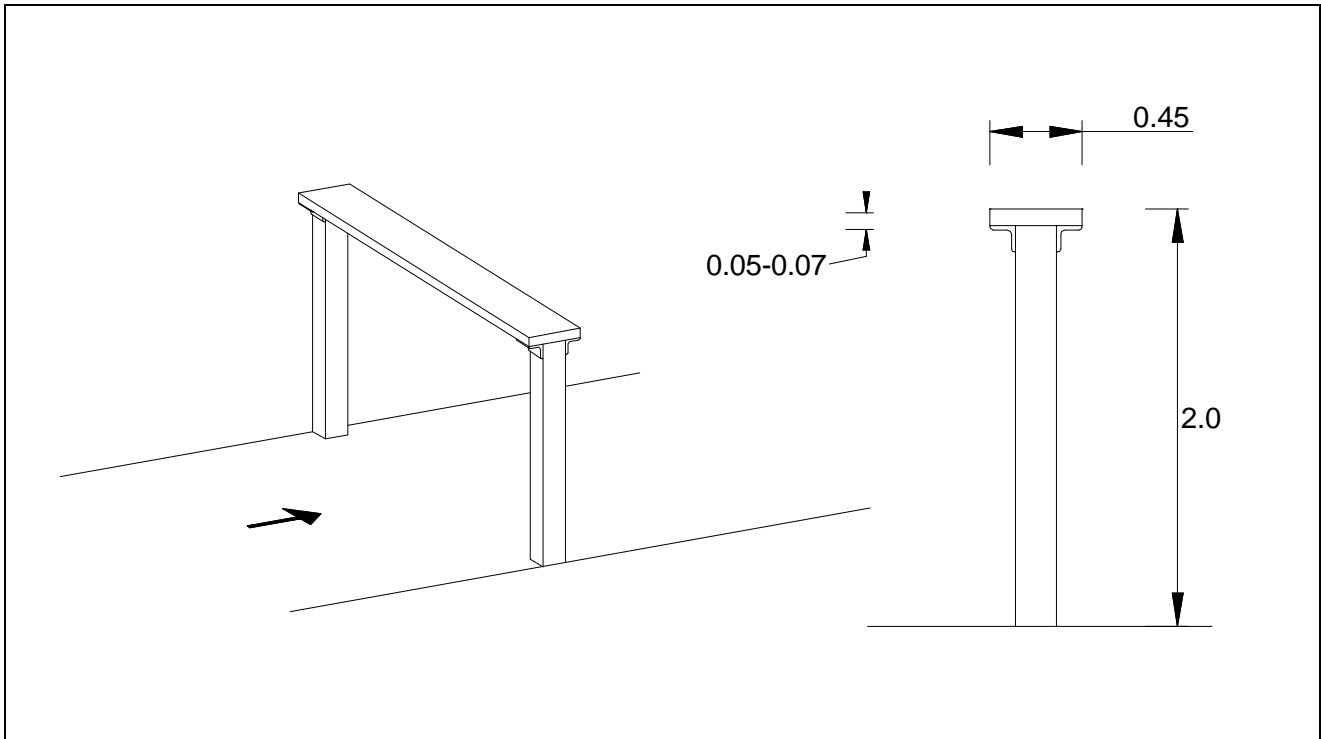

Characteristics

Height.....	2.0 m
Width.....	0.45 m
Thickness of the board.....	5.0 – 7.0 cm

Crossing

Free style crossing of the board, provided that the competitor passes the obstacle in the running direction and does not use the uprights.

OBSTACLE 11

TUNNEL AND TWIN BEAMS

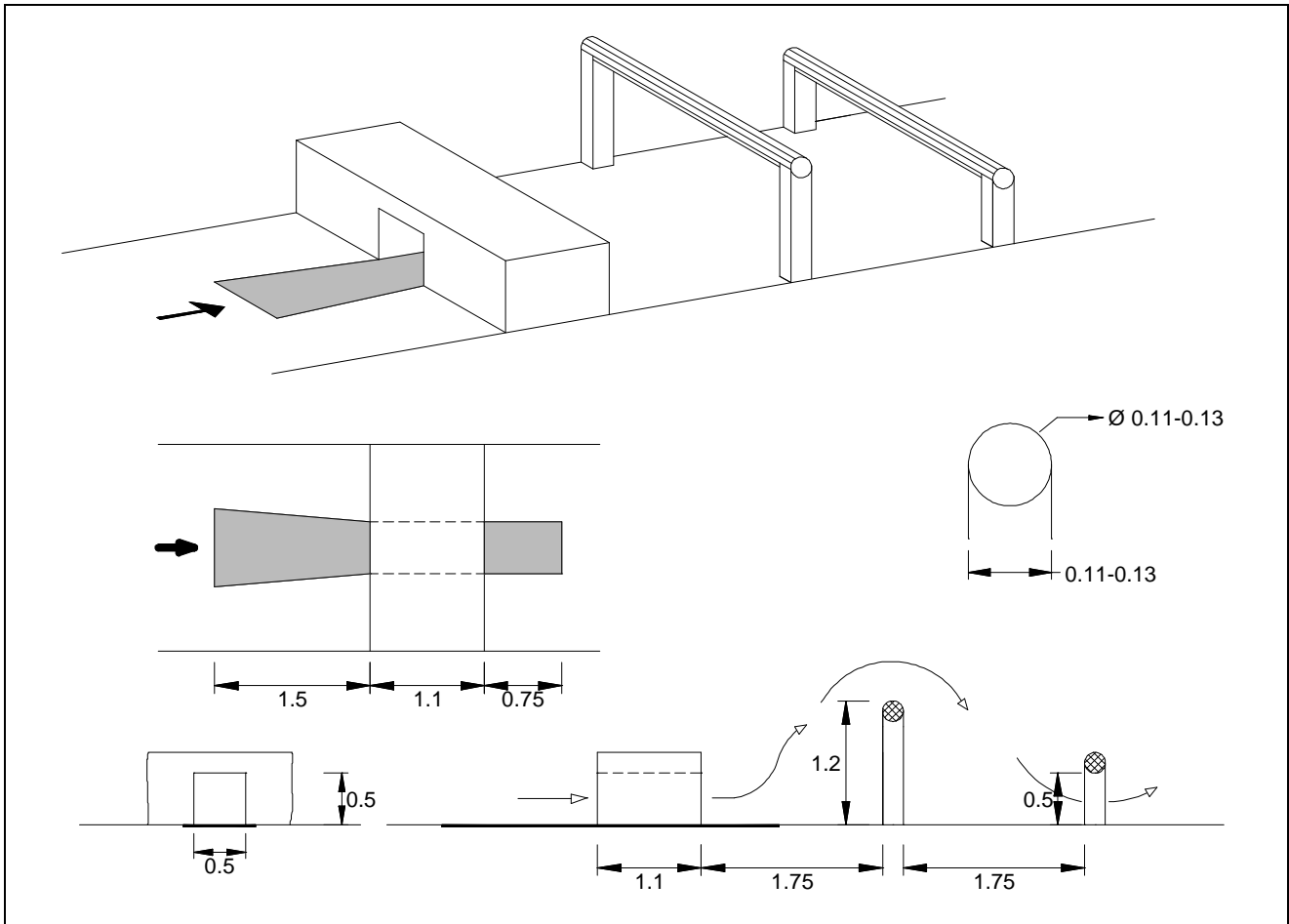

Characteristics

Height and breadth of the tunnel	0.5 m
Length of the tunnel	1.1 m
Height of first beam (upper edge)	1.2 m
Free space under the second beam (lower edge)	0.5 m
Distance between the different parts of the obstacle (horizontal plane)	1.75 m

For diving through the tunnel the surface of the ground must have a slippery surface. This slippery surface must commence 1.5 m ahead of the tunnel and end 0.75 after the tunnel.

Dimensions of the beams:

Diameter of tubular beams	11.0 - 13.0 cm
---------------------------------	----------------

Crossing

Negotiate the obstacle in the following sequence: Dive through the tunnel, climb over the first beam and pass under the second beam.

OBSTACLE 12

FOUR STEPS OF BEAMS

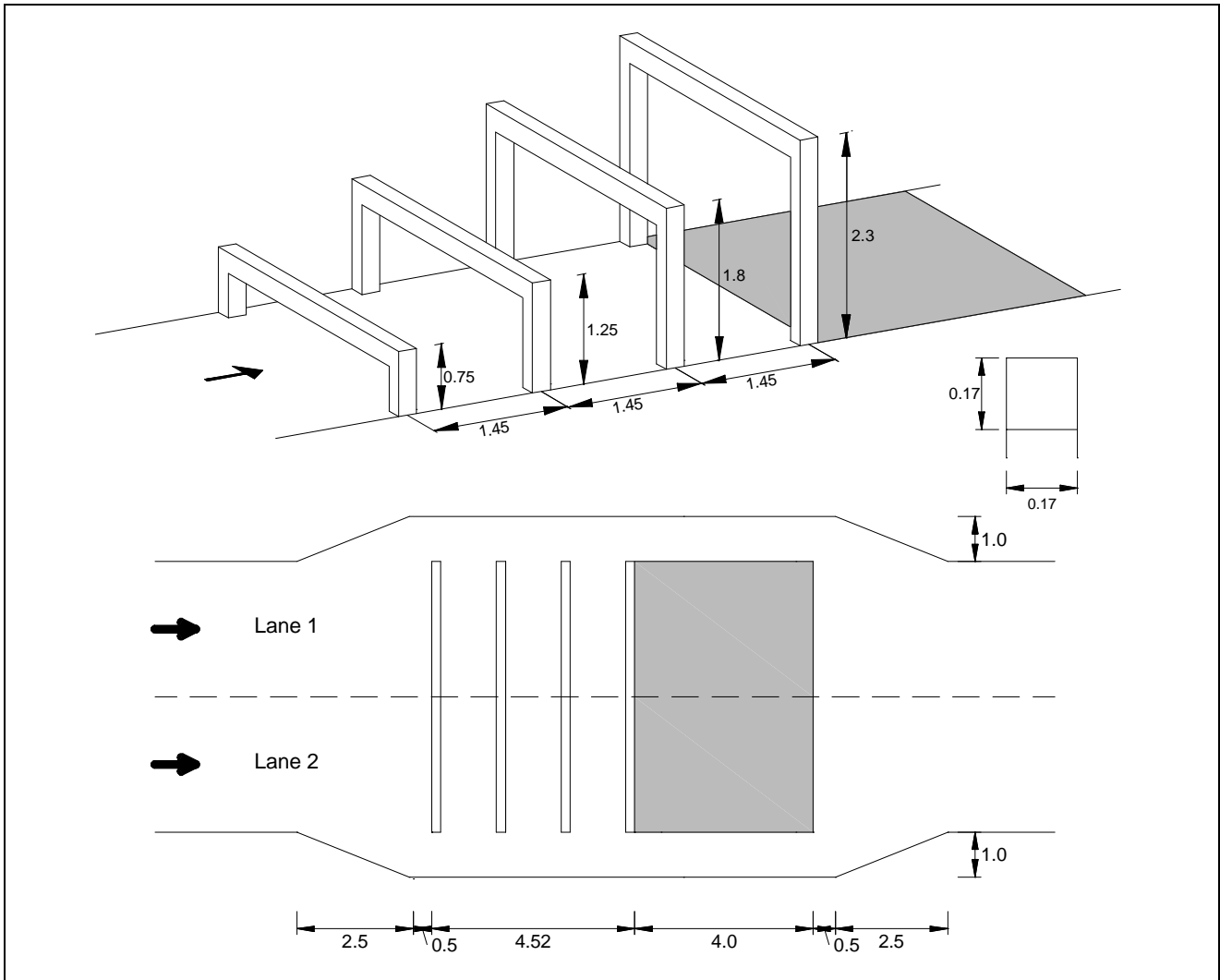

Characteristics

Four horizontal beams

Height of 1st beam.....	0.75 m
Height of 2nd beam.....	1.25 m
Height of 3rd beam	1.80 m
Height of 4th beam.....	2.30 m
Distance between the beams (centre to centre - horizontal plane).....	1.45 m
Length of landing pit.....	4.00 m

Dimensions of the beams:

Flat surface.....	17 cm
If tubular beams are used exceptionally – diameter of the beams.....	16.5 – 19.5 cm

It is recommended to expand the firm surface of the lanes on both sides of the obstacle (passages) to enable unhindered passing for female competitors (see page 22 figure 1).

Crossing

Free style passing over all beams.

OBSTACLE 13

BANQUETTE AND PIT

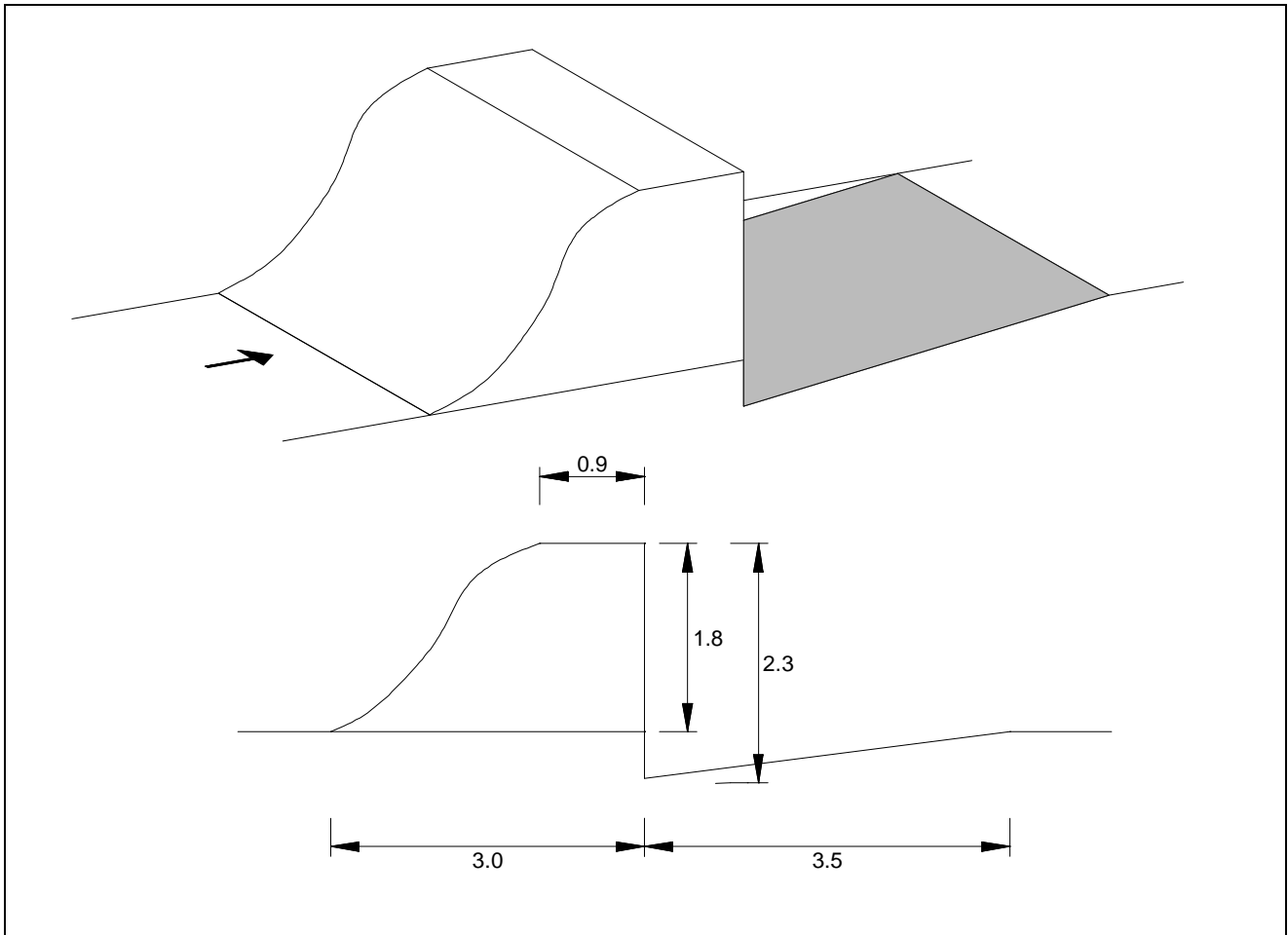

Characteristics

Height of embankment.....	1.8 m
Depth of pit.....	0.5 m
Length of pit.....	3.5 m
Width of the flat top.....	0.9 m
Length of the basis of the embankment.....	3.0 m

Crossing

Free style crossing.

OBSTACLE 14

ASSAULT WALL

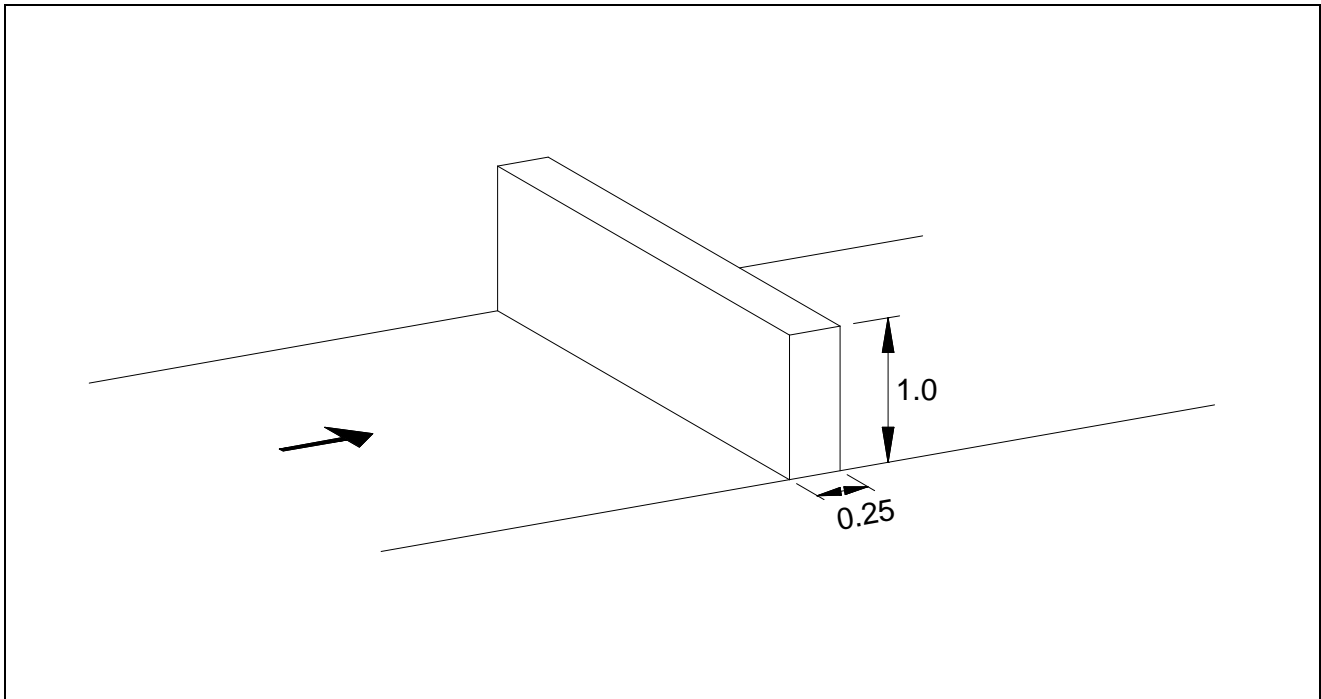

Characteristics

Height (upper edge) 1.0 m

Width 0.25 m

Crossing

Free style crossing.

OBSTACLE 15

PIT

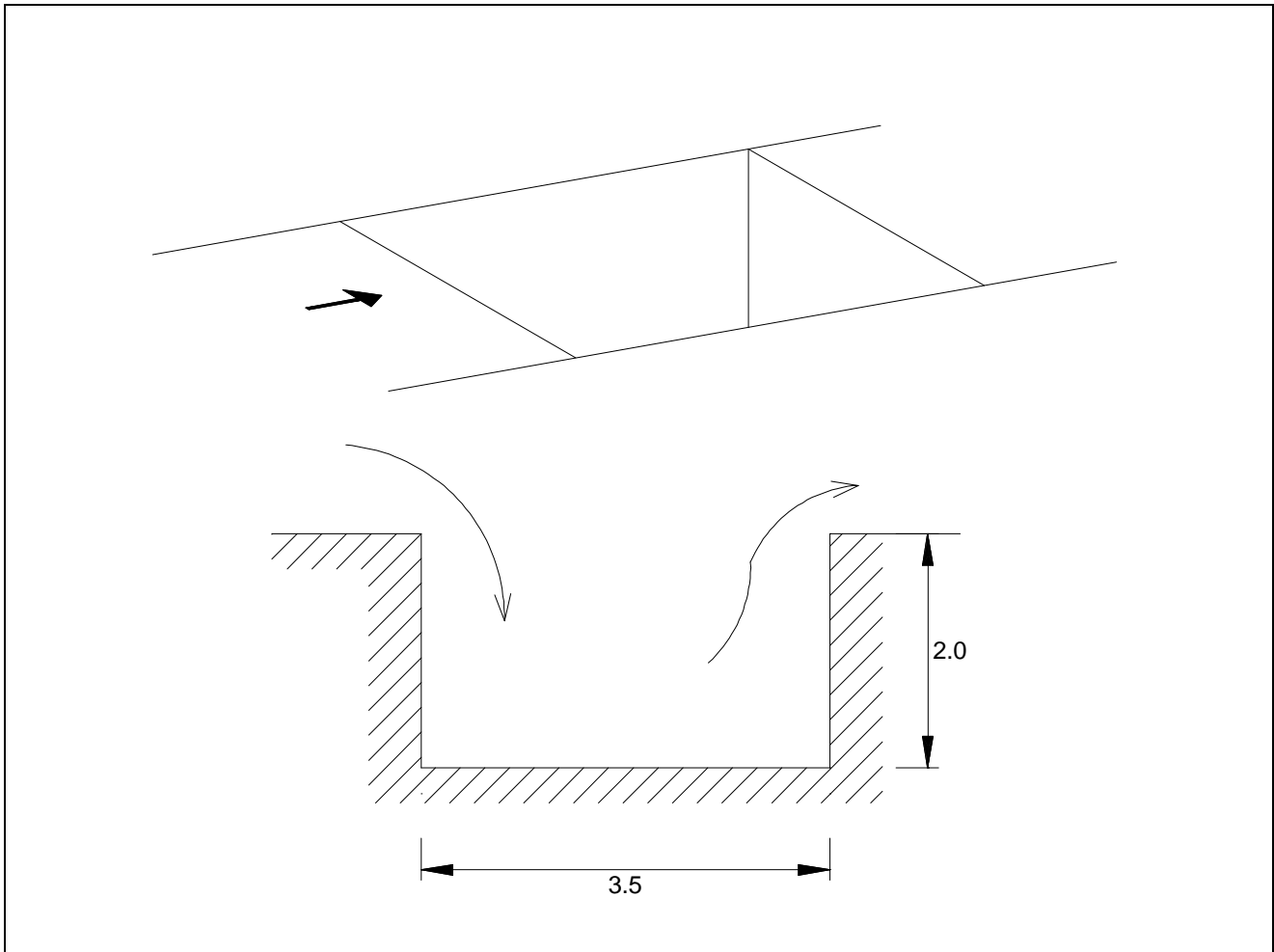

Characteristics

Depth.....2.0 m

Length3.5 m

The parapets of the pit have to be vertical. The track at the end of the pit in running direction has to be horizontal and must not give aid to the competitor when climbing out of the pit (i.e. giving extra grip on it). For competitions the ground of the pit should be of hard surface.

Crossing

Jump into the pit, and then climb the front parapet, without using the angles and the sides when going into or out of the pit.

OBSTACLE 16

VERTICAL LADDER

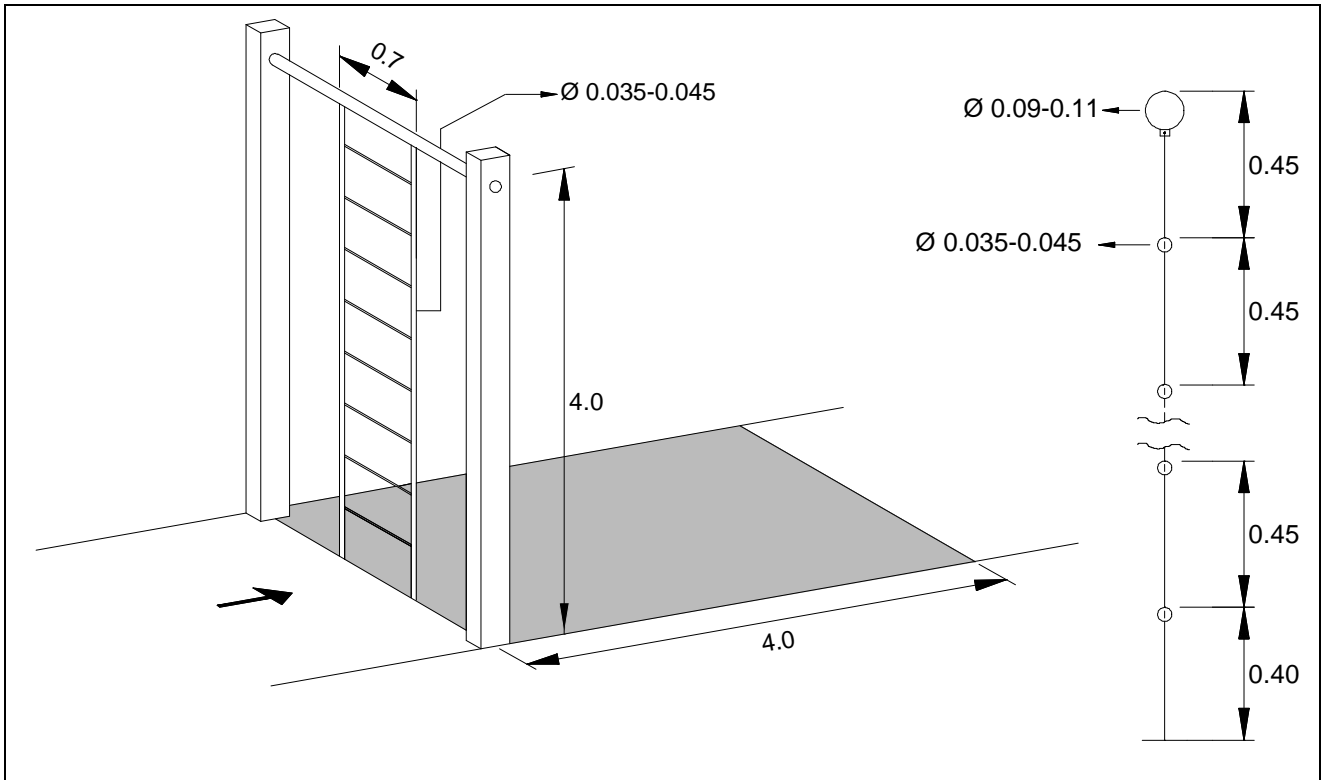

Characteristics

Height.....	4.0 m
Number of rungs.....	8
Width of rungs	0.7 m
Diameter of rungs.....	3.5 - 4.5 cm
Diameter of the ladder uprights.....	3.5 - 4.5 cm
Diameter of crossbar (must be tubular)	9.0 - 11.0 cm
Length of landing pit.....	4.0 m

The distance between the upper side of the rungs as well as the distance between the last rung and the upper side of the crossbar must be equal.

To ensure unhindered crossing of the crossbar the ladder must be fixed at the lower edge of the bar only.

It is recommended to expand the firm surface of the lanes on both sides of the obstacle (passages) to enable unhindered passing for female competitors (see page 22, figure 1).

Crossing

Free style climbing.

Cross the bar and descend or jump down to the prepared ground on the opposite side.

OBSTACLE 17

ASSAULT WALL II

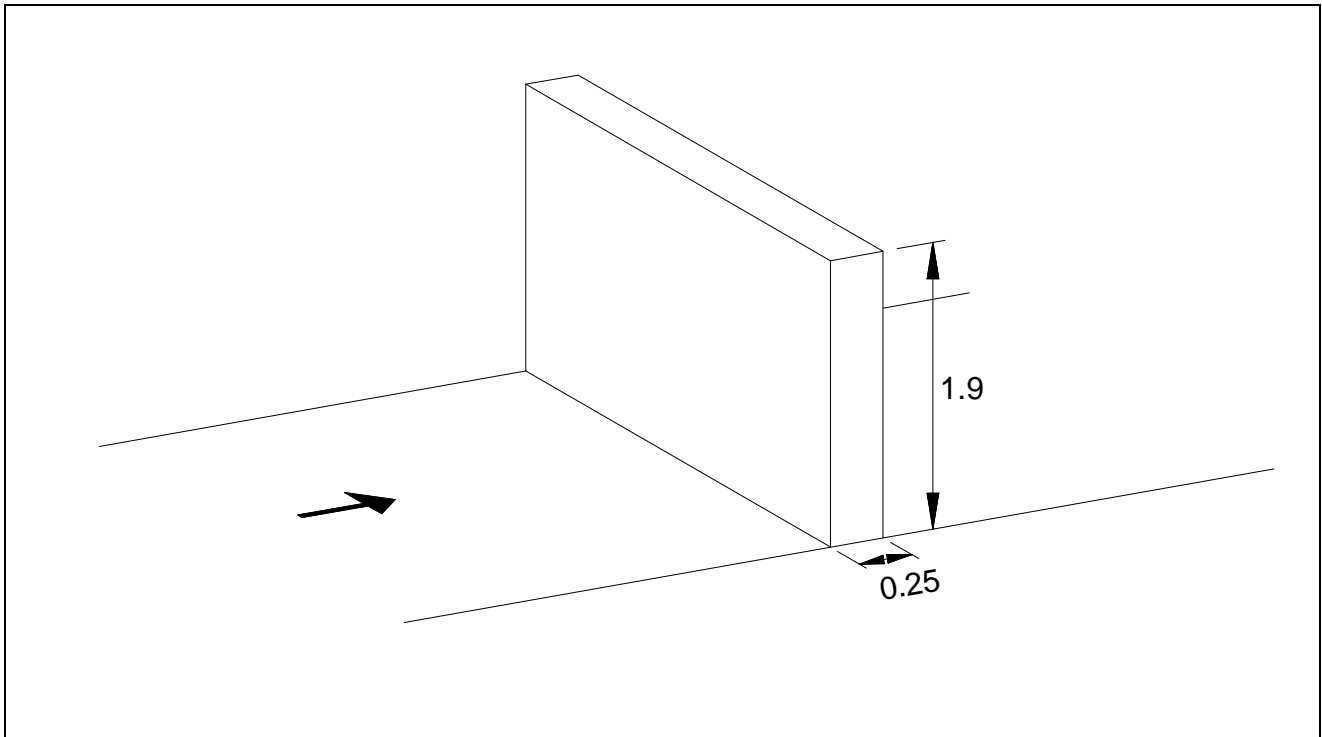

Characteristics

Height (upper edge)..... 1.9 m

Width..... 0.25 m

Crossing

Free style crossing.

OBSTACLE 18

BALANCE BEAM (ZIGZAG)

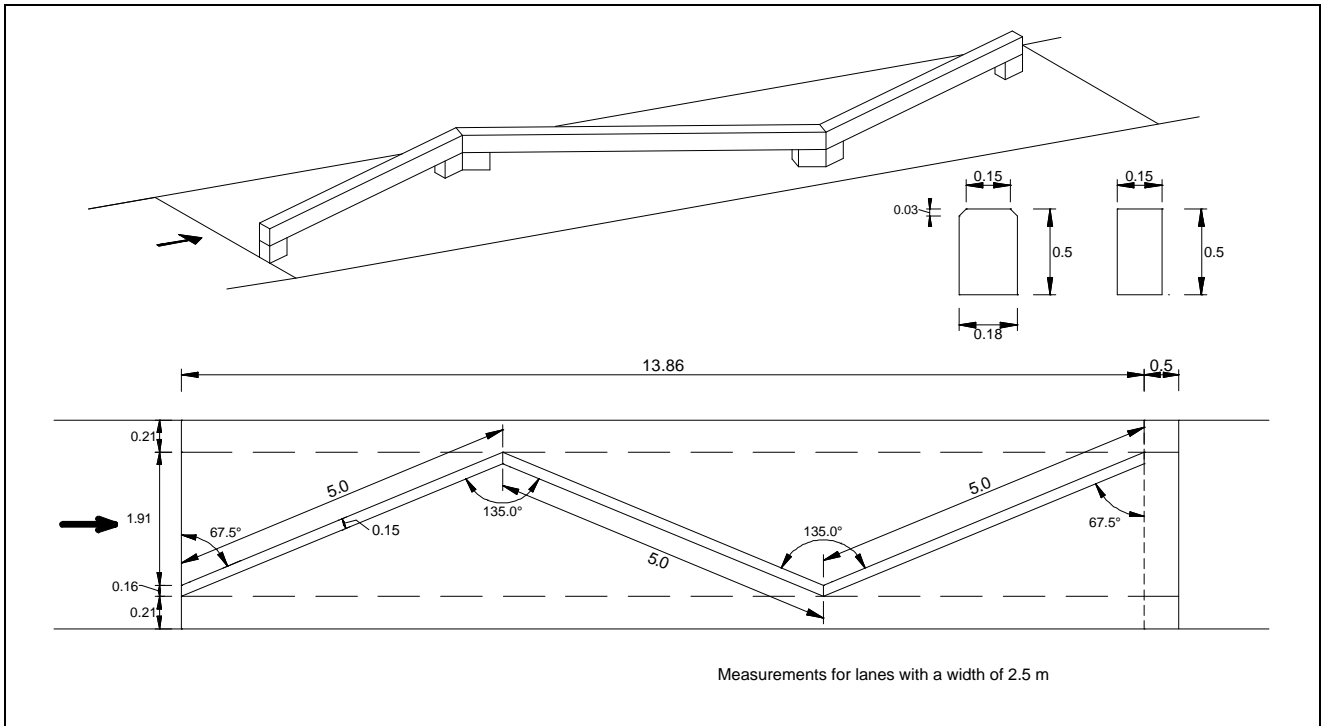

Characteristics

Three horizontal beams fixed obliquely to one another

Total length..... 14.36 m

Angle between the beams..... 135°

Angle of the first beam with the limiting line at the beginning of the obstacle..... 67.5°

Length of each beam 5.0 m

Height of horizontal beam (upper edge) 0.5 m

Width of the highest part of the flat beams..... 15 cm

Two limiting lines (width 5 cm) are part of the obstacle. The first line is placed at the beginning of the obstacle (0 – 5 cm), the other 45 – 50 cm beyond the end of the third beam.

If lanes with a width of less than the recommended 2.5 m are used, the obstacle will expand beyond the track. However, the distance between the edge of the track or lane lines at the beginning and at the end of the obstacle must be 20 cm in any case.

Crossing

Mount the beam ahead of the first line. Cross it lengthwise. At the far end jump to the ground beyond the limiting line.

Between the two lines, all loss of balance resulting in contact with the ground is considered a fault. The competitor must recommence in front of the line, marking the beginning of the obstacle.

OBSTACLE 19

CHICANE

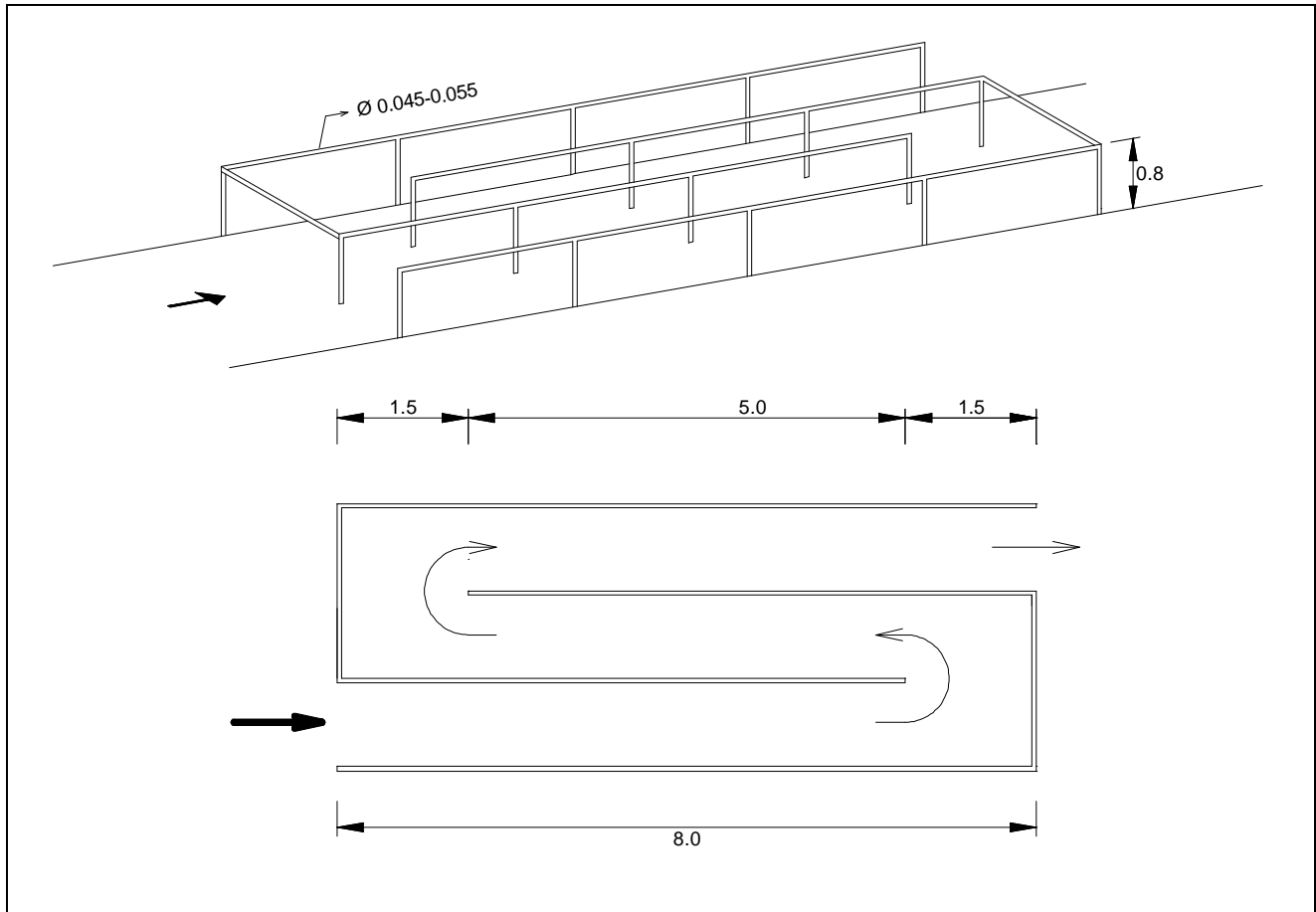

Characteristics

Length	8.0 m
Height of railing.....	0.8 m
Diameter of railing.....	4.5 – 5.5 cm

Crossing

Run through the chicane. The railing or the uprights may be used for support.

OBSTACLE 20

3 ASSAULT WALLS IN SUCCESSION

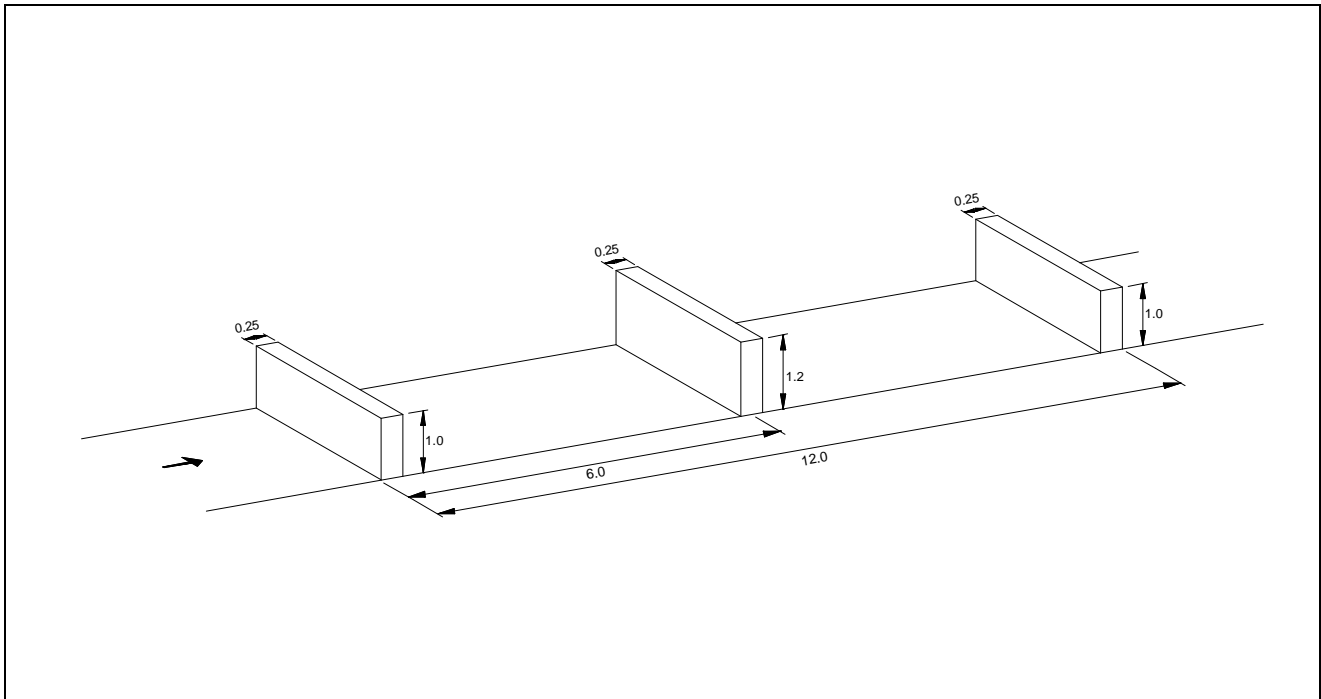

Characteristics

Height of 1st wall (upper edge).....	1.0 m
Height of 2nd wall (upper edge)	1.2 m
Height of 3rd wall (upper edge)	1.0 m
Width of walls	0.25 m
Total length from the beginning of the first wall to the end of the third wall	12.0 m
Distance from the beginning of the first wall to the centre of the second wall	6.0 m

Crossing

Walls to be crossed at the competitor's choice provided that the three walls are surmounted.

2. REGULATIONS FOR FEMALES

Same regulations as for male competitors, with following exceptions:

The following obstacles will not be negotiated:

Obstacle no. 1, 8, 12, and 16.

They must be passed outside the obstacle. The passages are supposed to be identical on both sides. If more than two lanes are available only the outer lanes will be used.

Dimensions of the passages:

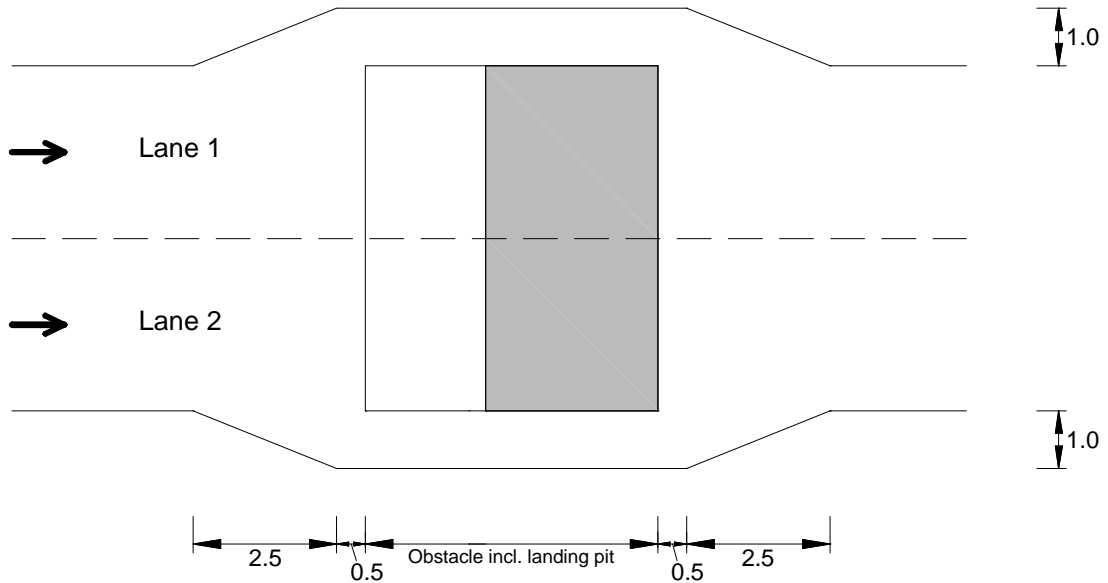

Figure 1: Passages

The surmounting of the following obstacles will be supported by removable boxes, one for each lane and obstacle:

Obstacle no. 10, 15, and 17.

The boxes are part of the track and must not be removed when female competitors are running. Boxes are placed in front of obstacle no. 10 (Irish table) in such a way that the rear side of the box is exactly beneath the front of the board projected vertically to the ground. At obstacles no. 15 and 17 boxes are placed with the rear side directly to the wall in running direction. The surface of the boxes must not be slippery.

Dimensions of the boxes:

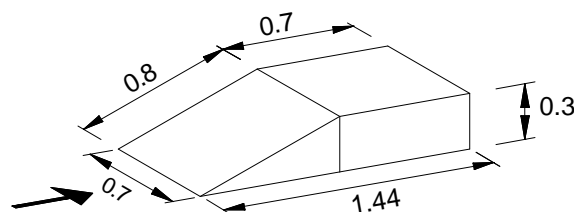

Figure 2: Box